



CONTRACT FOR EXHIBIT SPACE

We hereby contract for exhibit space at the 2017 IEEE WAMICON Conference to be held in Cocoa Beach, FL April 24-25, 2017. We agree to abide by the rules and regulations and with the Basic Terms and Conditions on the following pages of this form.

| | | | | |
|---|---------------|----------------------|---------------------|-----------------|
| Company Name: | | Contact Name: | | |
| Address (please <u>do not use P.O. Box #</u>): | | | | |
| City: | State: | Province: | Postal Code: | Country: |
| Telephone: | | Fax: | | |
| E-mail: | | WebSite: | | |

BOOTH LOCATION PREFERENCE (see layout diagram on page 2)

| | | |
|---------------|----------------|---------------|
| First Choice: | Second Choice: | Third Choice: |
|---------------|----------------|---------------|

| | Cost | Quantity | Total Cost |
|--|---------|----------|------------|
| 6' Table-top Space | \$950 | | |
| 10' Booth Space | \$1,200 | | |
| Additional conference passes (includes lunch, technical sessions, and banquet ticket) are available for purchase at a discount for exhibiting companies (Member Rate in Advance) | \$500 | | |
| Additional conference passes (includes lunch, technical sessions, and banquet ticket) are available for purchase at a discount for exhibiting companies (Non-member Rate in Advance) | \$600 | | |

10% discount for Exhibition Space paid for by 12/31/2016

| | | | | |
|--|------------------------|------------------|-------------------|-------------------------|
| We wish to be located as close as possible to the following companies: | | | | |
| If possible, please do not locate our space adjacent to or directly across from the following companies: | | | | |
| Product/Services to be exhibited: | | | | |
| We are: | Manufacturer | Manufactures Rep | Reseller | Testing / Certification |
| | Industrial Distributor | Publisher | Government Agency | Other |

All checks must be made in US Funds - Exhibitors are responsible for bank collection fees
Make all checks Payable to: 2017 IEEE WAMICON

AUTHORIZATION

I am authorized by my company to contract for exhibit space at the 2017 IEEE WAMICON as indicated above. I have carefully read and accept the information and conditions contained herein.

Print Name: _____ Date: _____

Signature: _____ Title: _____

PLEASE RETURN COMPLETED FORM AND PAYMENT TO:
 2017 IEEE WAMICON
 Attn: Holly Dunleavy
 3802 Spectrum Boulevard – Suite 130
 Tampa, FL 33612

Please send an electronic copy of this completed form to the WAMICON 2017 Exhibits and Sponsorship Co-Chairman Jim Assurian, Reactel, Incorporated – jassurian@reactel.com • Credit card payment is available online at www.wamicon.org contact Holly Dunleavy – Modelithics hdunleavy@modelithics.com • In case of difficulties please contact the Conference General Chair Craig Sapashe – craig_sapashe@keysight.com



Exhibit Floor Plan – Lobby Area

 Electrical Outlet

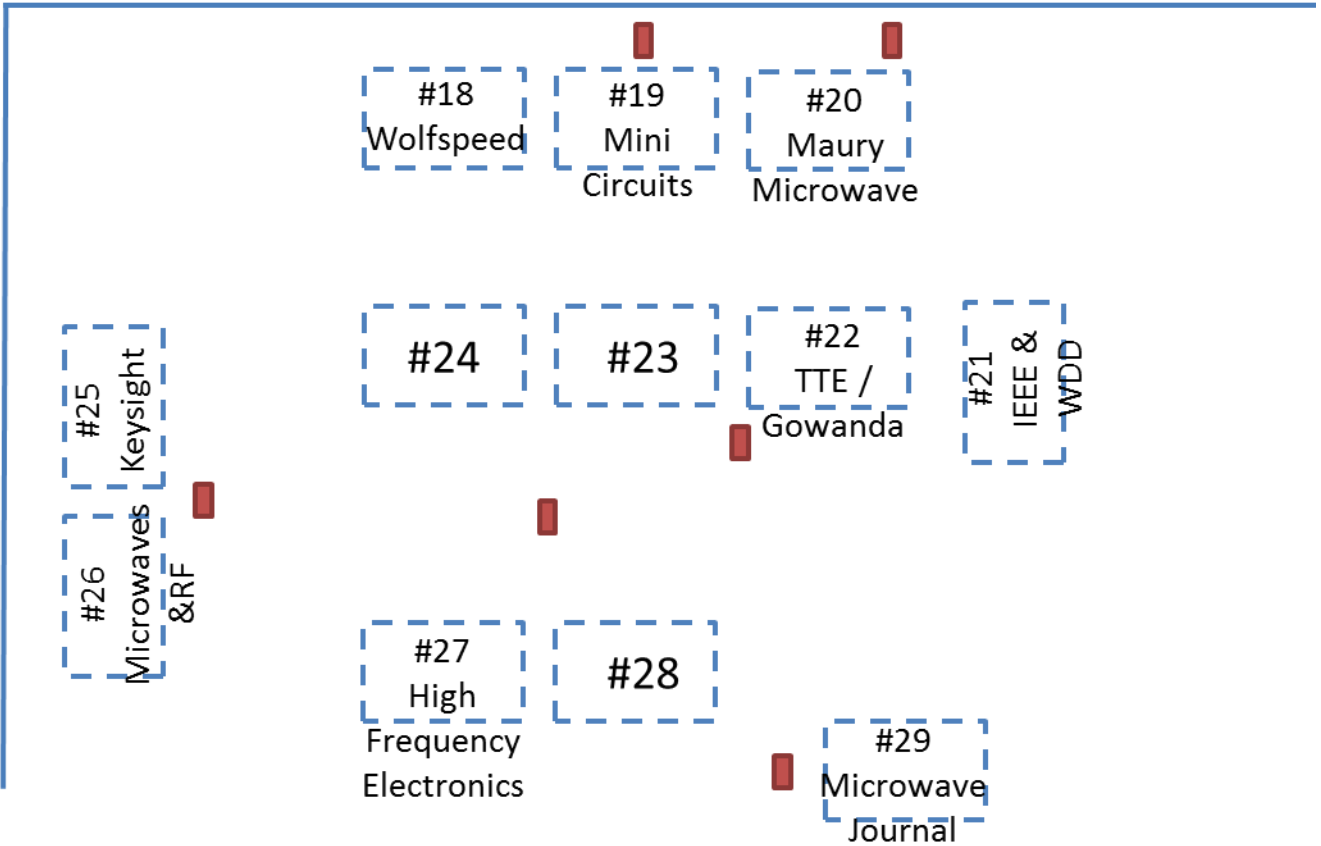
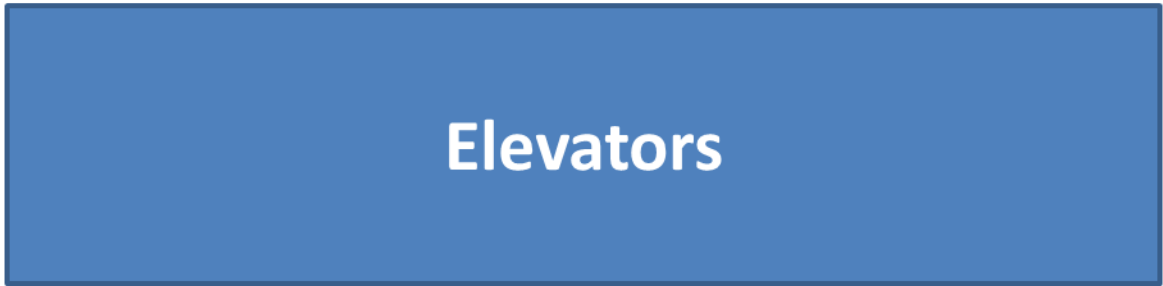



Exhibit Floor Plan - Seashore Ballroom

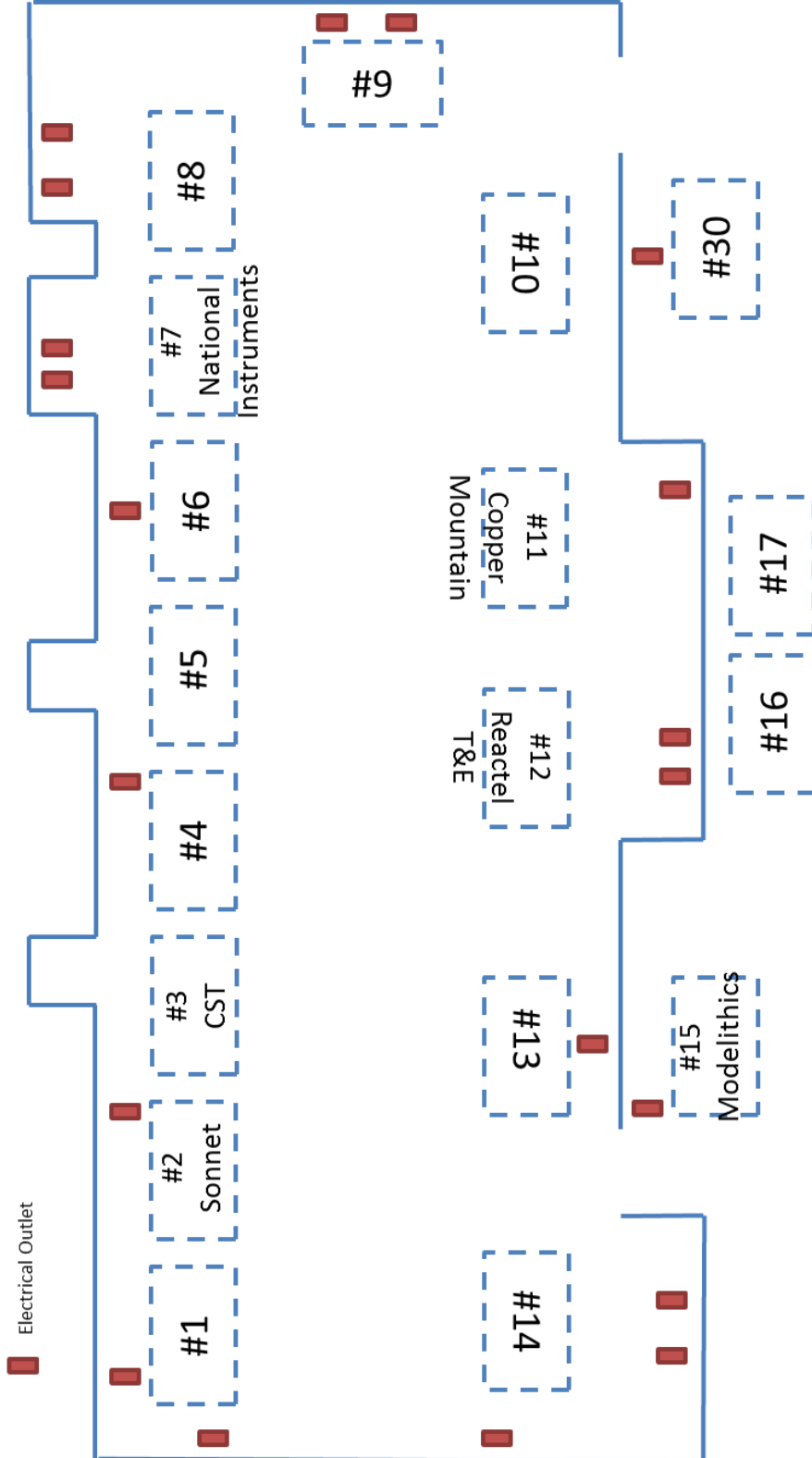
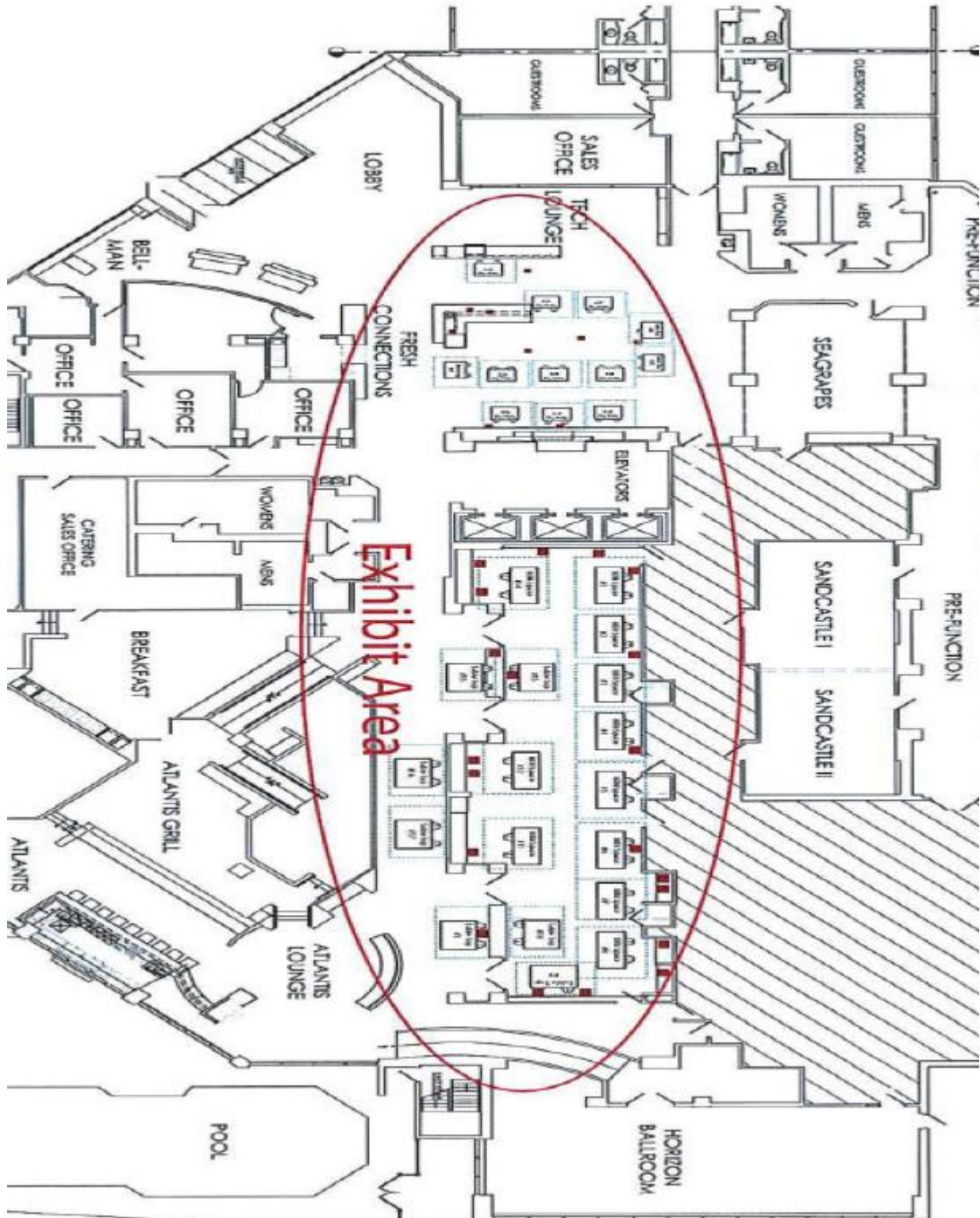



Exhibit Floor Plan - Overall View





Basic Terms and Conditions

1. Contract

This application, properly executed by Applicant (Exhibitor) shall, upon written acceptance and notification of booths assigned by the organizing committee for the 18th IEEE Wireless and Microwave Technology Conference 2017 hereby referred to as WAMICON 2017, constitute a valid and binding contract.

2. Assignment of Space

Assignment of space to exhibitors and those making application will be made in the order of postmark, fax or email date.

WAMICON 2017 will continue to receive applications and assign exhibit space, as it remains available, until shortly before the show opening date. In all cases, total booth payment must be received prior to show opening. After assignment, space location may not be changed, transferred or canceled by the Exhibitor **except** upon written request and with the subsequent written approval of WAMICON 2017 management. WAMICON 2017 management reserves the right to reassign Exhibitor space or to modify floor plan for overall benefit of the show.

3. Subletting Space

No exhibitor will assign, sublet, or apportion the whole or any part of the space allotted to him, nor exhibit therein, nor permit any other person or party to exhibit therein, nor any other goods, apparatus, etc. not manufactured or distributed by the Exhibitor in the regular course of his business except upon prior written consent of 2017 IEEE WAMICON organizing committee, also known as the steering committee.

4. Exhibit Space Rental Rates

Exhibit space rental includes materials and services described herein.

Show Price per 6' table-top space and 10' booth space: Exhibit space and draped table with chair. Booths (pop up or otherwise) are not permitted in 6' space. Exhibit area will be carpeted and cleaned daily.

5. Payment Requirements and Cancellation Charges

Applications require full payment before final booth assignment is confirmed in writing. All applications received after 03/01/17 must be accompanied by full payment.

All cancellations must be made in writing and will be based on the following schedule of refunds:

Space reductions are considered cancellations and may be subject to cancellation fees.

On or before 03/01/17...50% of total booth cost will be refunded. After 03/01/17 NO Refund will be permitted. "No-show" exhibitors will receive no refund.

It is understood that WAMICON 2017 reserves the right, at its option, to reassign a cancelled booth regardless of the cancellation rate assessed.

In the event that the premise in which the WAMICON 2017 Show is conducted shall become, in the sole discretion of WAMICON 2017, unfit for occupancy, or substantially interfered with by reason of any cause or causes not reasonably within the control WAMICON 2017, this agreement may be terminated by WAMICON 2017. For this purpose, the term "cause or causes" shall include, but not by way of limitation, fire, flood, epidemic, earthquake, explosion or accident, blockage, embargo, inclement weather, governmental restraints, restraints or orders of civil defense, or military authorities, act of public enemy, riot or civil disturbance, strike, lockout, boycott or other labor disturbance, inability to secure sufficient labor, technical, or other personnel, failure, impairment or lack of adequate transportation facilities, inability to obtain, or condemnation, requisition or commandeering of necessary supplies or equipment, local, state or federal law, ordinance, rule, order, decree or regulation, whether legislative, executive, or judicial, and whether constitutional, or act of God. Should WAMICON 2017 terminate this agreement pursuant to the provision of this paragraph the Exhibitor waives any and all claims for damages and agrees that WAMICON 2017 may, after computing the total amount of WAMICON 2017 cost and expenses in connection with its preparation for and conducting of the WAMICON 2017 Show, (including a reasonable reserve for claims and other contingencies) Space reductions are considered cancellations and may be subject to cancellation fees.

6. Exhibit Booth Manning and Dismantling Schedule

A representative must man exhibit space during all times when Exhibition is officially open. Exhibit space must be maintained in a neat and orderly manner throughout the Exhibition. Exhibitors may begin dismantling **only** after the closing of the exhibition, 04/25/15 at 4:00pm. Move-out **must** be completed by within 3 hours after closing of the exhibition. Exhibitors are responsible for removal of all materials used in their display. Any exhibitor leaving materials after 04/25/17 at 8:00 pm may be charged for the materials' removal. Failure to observe this rule, including early dismantling, may result in up to \$500 (U.S. Currency) fine and will jeopardize the exhibitor's space assignments or right to exhibit at future conferences.

7. Loss or Damage

Exhibitor agrees that WAMICON 2017 shall not be liable for any damage or liability of any kind or for any loss, damage or injury to persons or property during the term of this agreement, from any cause whatsoever by reason of use, occupation and enjoyment of exhibit space by Exhibitor or any person thereon with the consent of Exhibitor, and that Exhibitor will defend, indemnify and save harmless, WAMICON 2017 from all liability whatsoever, on account of any such damage, or injury, whether or not caused by



negligence or breach of an obligation by Exhibitor or its employees or representatives.

Exhibitor will be liable for all damages or liability of any kind or for any loss, damage or injury to persons or any property during the show from any cause whatsoever by reason of use, occupation and enjoyment of exhibit space.

8. Demonstrations

No demonstrations or solicitations shall be permitted outside of the Exhibitor's assigned space, and no signs or placards may be displayed on persons or otherwise outside exhibit spaces.

9. Compliance

The Exhibitor assumes all responsibility for compliance with all pertinent ordinances, regulations and codes of duly authorized local,

State and federal governing bodies concerning fire, safety and health, together with the rules and regulations of the operators and/or owners of the property wherein the Show is held.

10. Unions

It is further agreed that the Exhibitor will abide by and comply with rules and regulations concerning local unions having agreements with the Show Facility or with authorized contractors employed by WAMICON 2017.

11. Management

The Exhibitor further agrees that the conditions, rules and regulations of the WAMICON 2017 management are made a part of this contract and that said Exhibitor agrees to be bound by each and all of these rules and regulations, and that the management shall have the full power to interpret, amend and enforce all rules and regulations in the best interest of the Show.